

REV	DESCRIPTION	DATE	APPROVED
A	新版发行	2024.05.08	HHM

SPECIFICATION:

- ELECTRICAL:
 - CURRENT RATING:5A;
 - CONTACT RESISTANCE:40mΩ Max;
 - DIELECTRIC WITHSTANDING VOLTAGE:100V AC;
 - INSULATION RESISTANCE:100 MΩ MIN;
- MECHANICAL:
 - MATING FORCE:5~20N;
 - UNMATING FORCE:8~20N;
 - DURABILITY:10000 CYCLES;6~20N AFTER DURABILITY TEST;
- MATERIAL:
 - HOUSING&MOLDING:BLACK LCP UL94V-0;
 - TERMINAL:C7025 T=0.15mm;
 - SHELL:SUS304 T=0.30mm;
 - MID PLATE:SUS304 T=0.15mm;
- PLATING SPECIFICATION:
 - TERMINAL:CONTACT POINT GOLD PLATED 3u "Min
PIN WELDING AREA GOLD PLATED 1u" Min.
 - NI 40u" Min. UNDER PLATED OVER ALL.
 - SHELL:PLATED Ni 50u" MIN(Salt spray 48H)
- ELECTROPLATED PRODUCTS NEED TO UNDERGO TIN ADHESION TESTING: THE TIN ADHESION AREA SHOULD REACH OVER 95%.
- SMT REFLOW SOLDERING (PEAK VALUE 260 ° C ± 5 ° C) SHALL BE FREE OF BLISTERING, GLUE MELTING AND POOR COLOR CHANGE (DEFORMATION WITHIN TOLERANCE)
- OPERATING TEMPERATURE: -40° C~+85° C

A1	GND	B12	GND
A4	VBUS	B9	VBUS
A5	CC1	B8	SBU2
A6	D+	B7	Dn2
A7	D-	B6	Dp2
A8	SBU1	B5	CC2
A9	VBUS	B4	VBUS
A12	GND	B1	GND
PIN	SIGNAL NAME	PIN	SIGNAL NAME

CUSTOMER DRAWING			铭创科技(东莞)有限公司 Mingchuang Technology (Dongguan) Co., Ltd.		
UNITS mm	SCALE 1:1	SHEET 1 OF 2	TITLE TYPE C母座16PIN 立式四脚插板DIP L=24.5 A款		
PROJECTION: 		DRAW: DAP	MAT'L SEE TABLE		
GENERAL TOLERANCE .000 ±0.15 .00 ±0.20 .0 ±0.25 .0 ±2° .00 ±1°		CHECK: HWT	FINISH SEE TABLE		
		APPD: HHM	DWG. NO. A031610A	PART NO.	SIZE A4



REV	DESCRIPTION	DATE	APPROVED
A	新版发行	2024.05.08	HHM

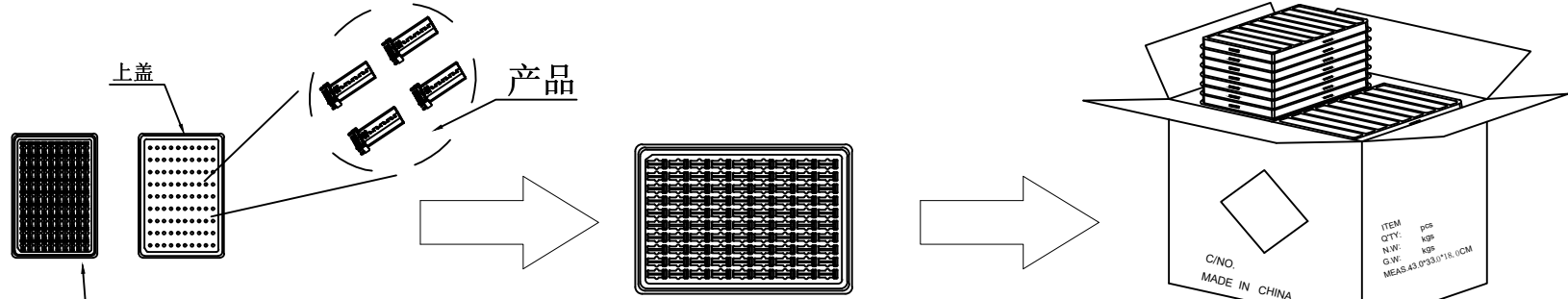

- ① PE真空盒(1Set).
- ② 90PCS/盒
- ③ 50盒/箱(4.5K).

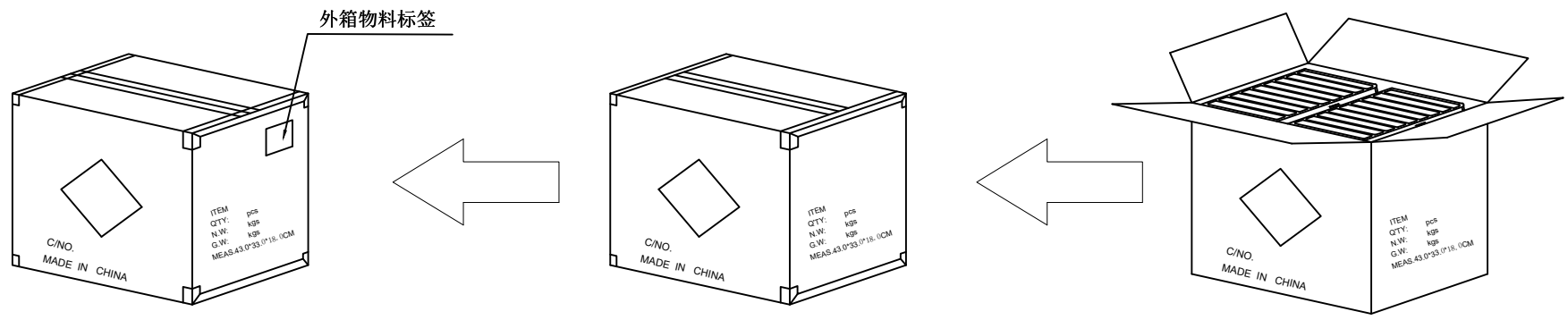

- ④ 每箱竖放25盒*2, 若尾数箱在空间处加装填充物.
- ⑤ 外箱用透明胶纸带封“工”字型.
- ⑥ 依图示粘贴产品或RoHS标签.

04	纸箱	B-05-0004	430mm*330mm*180mm	1 PCS
03	上盖	B-01-0016	PET透明 T0.3*L305*W205*H11mm	50 PCS
02	下盒	B-01-0015	PET透明 T0.3*L305*W205*H11mm	50 PCS
01	连接器	A031610A	16PIN, DIP	4500 PCS
序号	物料名称	物料编号	规格	描述

CUSTOMER DRAWING			铭创科技(东莞)有限公司 Mingchuang Technology (Dongguan) Co., Ltd.		
UNITS mm	SCALE 1:1	SHEET 2 OF 2	TITLE TYPE C母座16PIN 立式四脚插板DIP L=24.5 A款		
PROJECTION: 	DRAW: DAP		MAT'L SEE TABLE		
GENERAL TOLERANCE		CHECK: HWT	FINISH SEE TABLE		
.000 ±0.15		APPD: HHM	DWG. NO. A031610A		PART NO. _____
.00 ±0.20			SIZE A4		
.0 ±0.25					
.0 ±2°					
.0 ±1°					