



REV	DESCRIPTION	DATE	APPROVED
A	新版发行	2023.07.18	HHM

SPECIFICATION:

- ELECTRICAL:
  - CURRENT RATING:5A;
  - CONTACT RESISTANCE:40mΩ Max;
  - DIELECTRIC WITHSTANDING VOLTAGE:100V AC;
  - INSULATION RESISTANCE:100 MΩ MIN;
- MECHANICAL;
  - MATING FORCE:5~20N;
  - UNMATING FORCE:8~20N;
  - DURABILITY:10000 CYCLES;6~20N AFTER DURABILITY TEST;
- MATERIAL:
  - HOUSING&MOLDING:LCP BLACK UL94V-0;
  - TERMINAL:C7025 T=0.15mm;
  - SHELL:SUS304 T=0.30mm;
  - MID PLATE:SUS304 T=0.15mm;
- PLATING SPECIFICATION:
  - TERMINAL:CONTACT POINT GOLD PLATED 3u" MIN  
PIN WELDING AREA GOLD PLATED 1u" MIN.
  - NI 40U" MIN. UNDER PLATED OVER ALL.
  - SHELL:PLATED NI 50U" MIN(SALT SPRAY 48H)
- ELECTROPLATED PRODUCTS NEED TO UNDERGO TIN ADHESION TESTING: THE TIN ADHESION AREA SHOULD REACH OVER 95%.
- SMT REFLOW SOLDERING (PEAK VALUE 260 ° C ± 5 ° C) SHALL BE FREE OF BLISTERING, GLUE MELTING AND POOR COLOR CHANGE (DEFORMATION WITHIN TOLERANCE)
- OPERATING TEMPERATURE: -40 ° C~+85 ° C

A1	GND	B12	GND
A4	VBUS	B9	VBUS
A5	CC1	B8	SBU2
A6	D+	B7	D-
A7	D-	B6	D+
A8	SBU1	B5	CC2
A9	VBUS	B4	VBUS
A12	GND	B1	GND
PIN	SIGNAL NAME	PIN	SIGNAL NAME

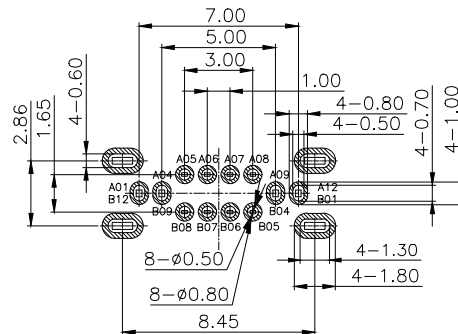
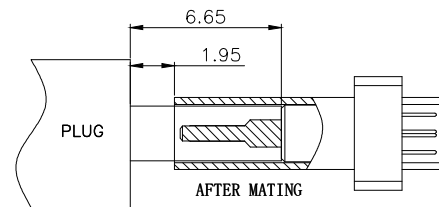
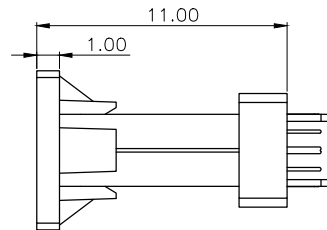
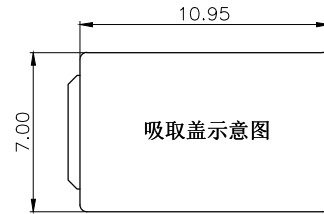
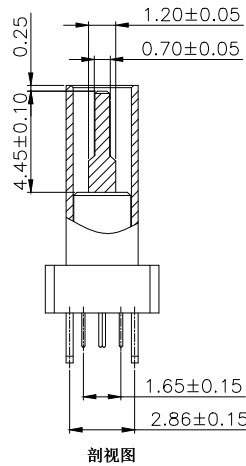
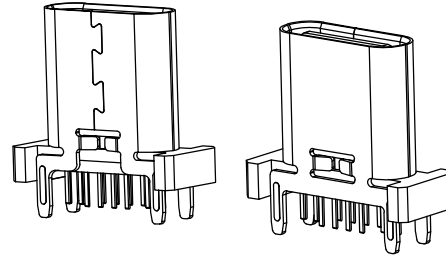
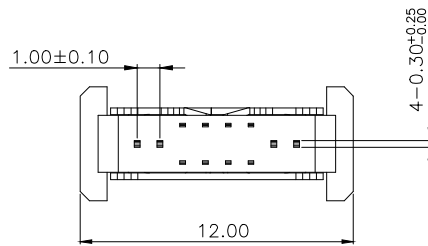
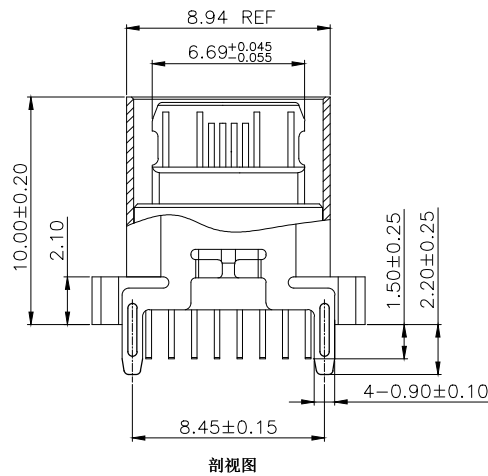
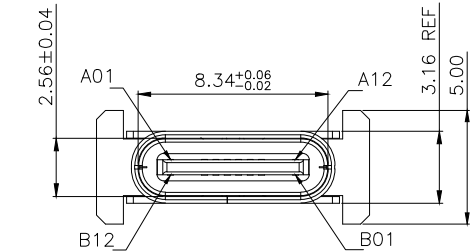

RECOMMENDED P.C.B. LAYOUT(俯视图)  
TOLERANCE UNSPECIFIED ±0.05mm

CUSTOMER DRAWING		
UNITS mm	SCALE 1:1	SHEET 1 OF 2
PROJECTION: 	DRAW: DAP	
GENERAL TOLERANCE .000 ±0.15 .00 ±0.20 .0 ±0.25 .0 ±2° .00 ±1°	CHECK: HWT	APPD: HHM

铭创科技（东莞）有限公司 Mingchuang Technology (Dongguan) Co., Ltd.			
TITLE TYPE C母座16PIN 立式四脚插板DIP L=10.0 A款			
MAT'L SEE TABLE	FINISH SEE TABLE		
DWG. NO. A031624A	PART NO.	SIZE A4	



REV	DESCRIPTION	DATE	APPROVED
A	新版发行	2023.07.18	HHM

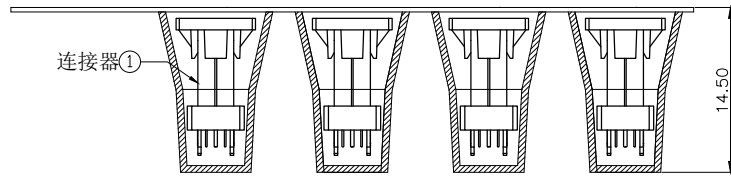
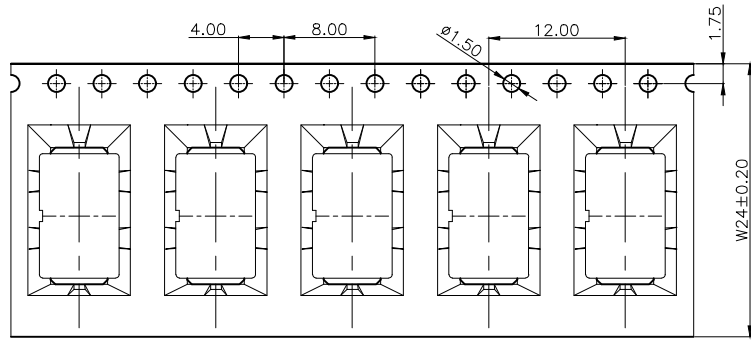

产品入载带示意图

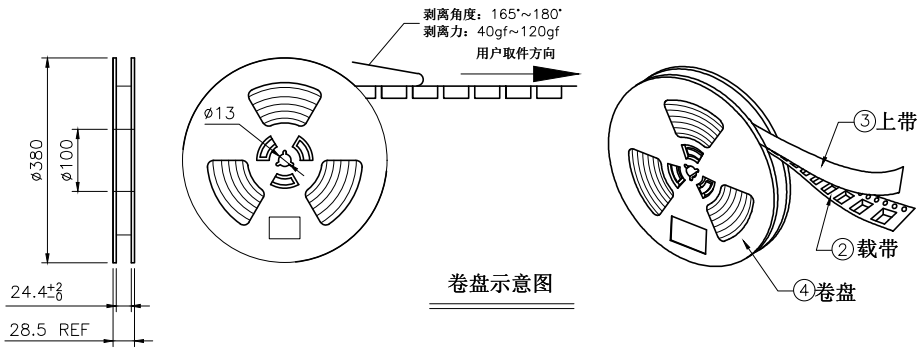

卷盘示意图

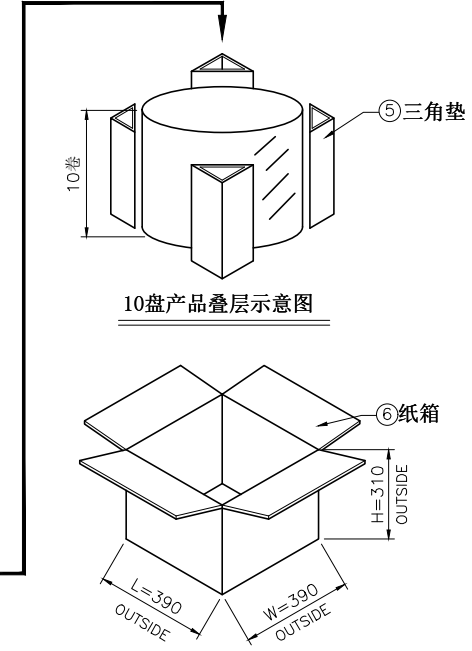
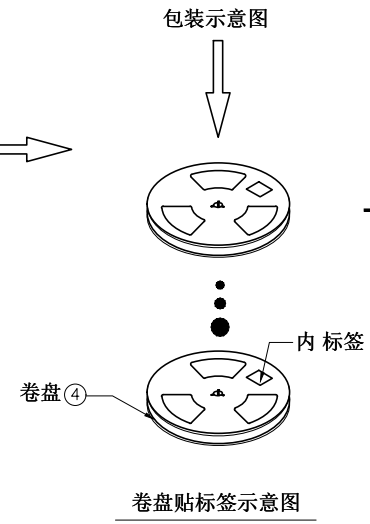

- 技术要求:
- 载带首尾各留出10PCS空格不装产品;
  - 每穴放置1PCS产品, 每卷装500PCS产品, 放置方式如图所示;
  - 将包装好的产品;每盘必需贴上内标签;将贴好内标签的产品每10盘堆叠。(如客户有要求, 请按客户要求包装出货)
  - 在纸箱四角垫上4个三角垫, 然后把装好产品的卷盘放入纸箱中, 最后用胶带封箱;
  - 上带与载带的剥离力: 40gf~120gf, 跳动量在30gf内; (剥离角度: 165°~180°, 剥离速度: 250~300mm/min)
  - 产品符合RoHS环保标准要求。

06	纸箱	B-05-0012	390mm*390mm*310mm	1 PCS
05	三角垫	/	300mm*260mm*7mm	4 PCS
04	卷盘	/	D=380mm, d=100mm, H=28.5mm	10 PCS
03	上带	/	W=20.7mm, T=0.05mm	6400 mm
02	载带	B-03-0011	W=24mm, T=0.50mm, P=12.0mm	6400 mm
01	连接器	A031624A	16PIN, DIP	5000 PCS
序号	物料名称	物料编号	规格	描述

CUSTOMER DRAWING			铭创科技(东莞)有限公司 Mingchuang Technology (Dongguan) Co., Ltd.		
UNITS mm	SCALE 1:1	SHEET 2 OF 2	TITLE		
PROJECTION: 		DRAW: DAP	TYPE C母座16PIN 立式四脚插板DIP L=10.0 A款		
GENERAL TOLERANCE		CHECK: HWT	MAT'L SEE TABLE	FINISH SEE TABLE	
.000 ±0.15	.00 ±0.20	APPD: HHM	DWG. NO. A031624A	PART NO.	SIZE A4
.0 ±0.25	.0 ±2°				
.0 ±1°					