

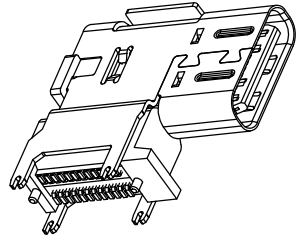

REV	DESCRIPTION	DATE	APPROVED
A	新版发行	2024.07.12	HHM



3D VIEW

SPECIFICATION:

- 一、ELECTRICAL:
 1. CURRENT RATING:5A;
 2. CONTACT RESISTANCE:40mΩ Max;
 3. DIELECTRIC WITHSTANDING VOLTAGE:100V AC;
 4. INSULATION RESISTANCE:100 MΩ MIN;
- 二、MECHANICAL;
 1. MATING FORCE:5~20N;
 2. UNMATING FORCE:8~20N;
 3. DURABILITY:10000 CYCLES;6~20N AFTER DURABILITY TEST;
- 三、MATERIAL:
 1. HOUSING&MOLDING: BLACK LCP UL94V-0;
 2. TERMINAL:C18400 T=0.15mm;
 3. SHELL:SUS304 T=0.30mm;
 4. MID PLATE:SUS301 T=0.15mm;
- 四、PLATING SPECIFICATION:
 1. TERMINAL:CONTACT POINT GOLD PLATED 3u"Min
PIN WELDING AREA GOLD PLATED 1u" Min.
 2. NI 40u" Min. UNDER PLATED OVER ALL.
 3. SHELL:PLATED Ni 50u" Min(Salt spray 48H)
- 五、ELECTROPLATED PRODUCTS NEED TO UNDERGO TIN ADHESION TESTING: THE TIN ADHESION AREA SHOULD REACH OVER 95%.
- 六、SMT REFLOW SOLDERING (PEAK VALUE 260 ° C ± 5 ° C) SHALL BE FREE OF BLISTERING, GLUE MELTING AND POOR COLOR CHANGE (DEFORMATION WITHIN TOLERANCE)
- 七、OPERATING TEMPERATURE: -40° C~+85° C

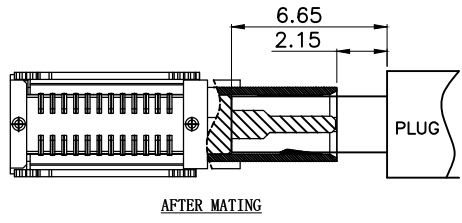
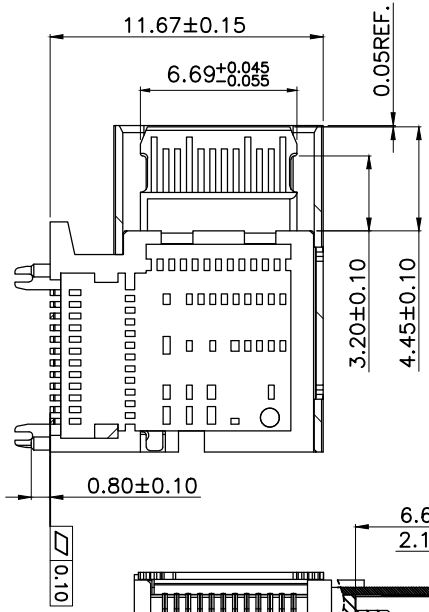
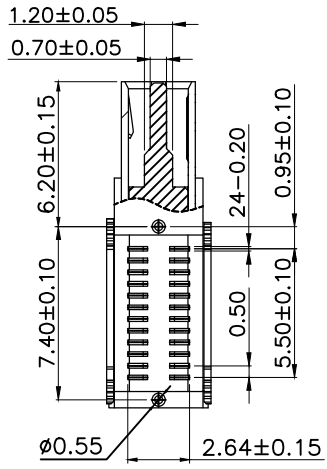
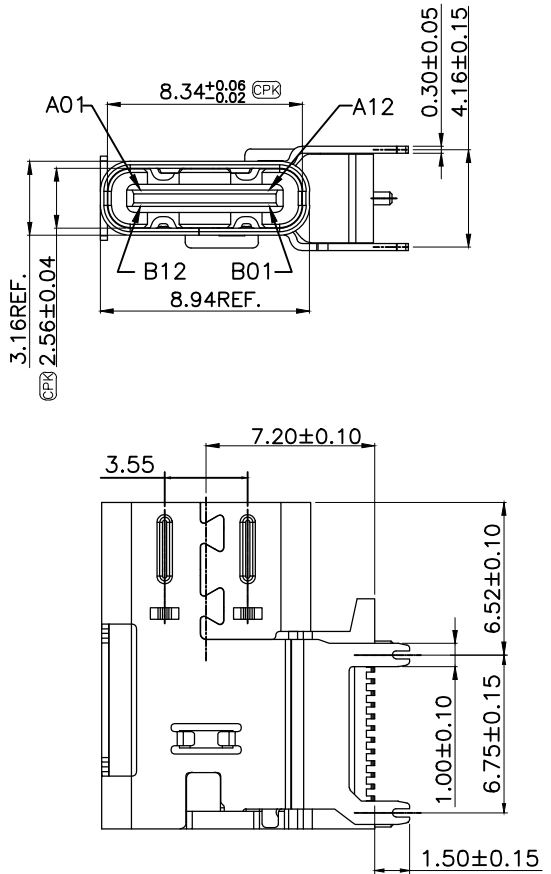

A1	GND	B12	GND
A2	TX1+	B11	RX1+
A3	TX1-	B10	RX1-
A4	VBUS	B9	VBUS
A5	CC1	B8	SBU2
A6	D+	B7	D-
A7	D-	B6	D+
A8	SBU1	B5	CC2
A9	VBUS	B4	VBUS
A10	RX2-	B3	TX2-
A11	RX2+	B2	TX2+
A12	GND	B1	GND
PIN	SIGNAL NAME	PIN	SIGNAL NAME

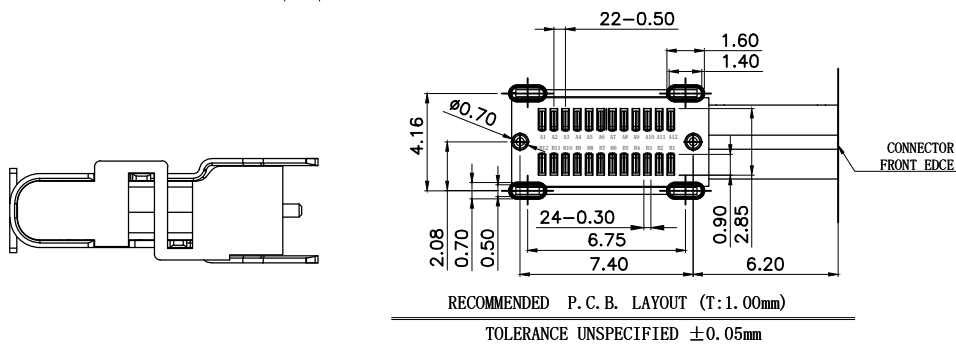

CUSTOMER DRAWING		
UNITS mm	SCALE 1:1	SHEET 1 OF 2
PROJECTION: 	DRAW: DAP	
GENERAL TOLERANCE .000 ±0.15 .00 ±0.20 .0 ±0.25 .0 ±2° .00 ±1°	CHECK: HWT	APPD: HHM

铭创科技（东莞）有限公司 Mingchuang Technology (Dongguan) Co., Ltd.			
TITLE TYPE C母座24PIN 侧贴四鱼叉脚插板SMT L=14.3 CH=7.20			
MAT'L SEE TABLE	FINISH SEE TABLE		
DWG. NO. A032411A	PART NO.	SIZE A4	



REV	DESCRIPTION	DATE	APPROVED
A	新版发行	2024.07.12	HHM

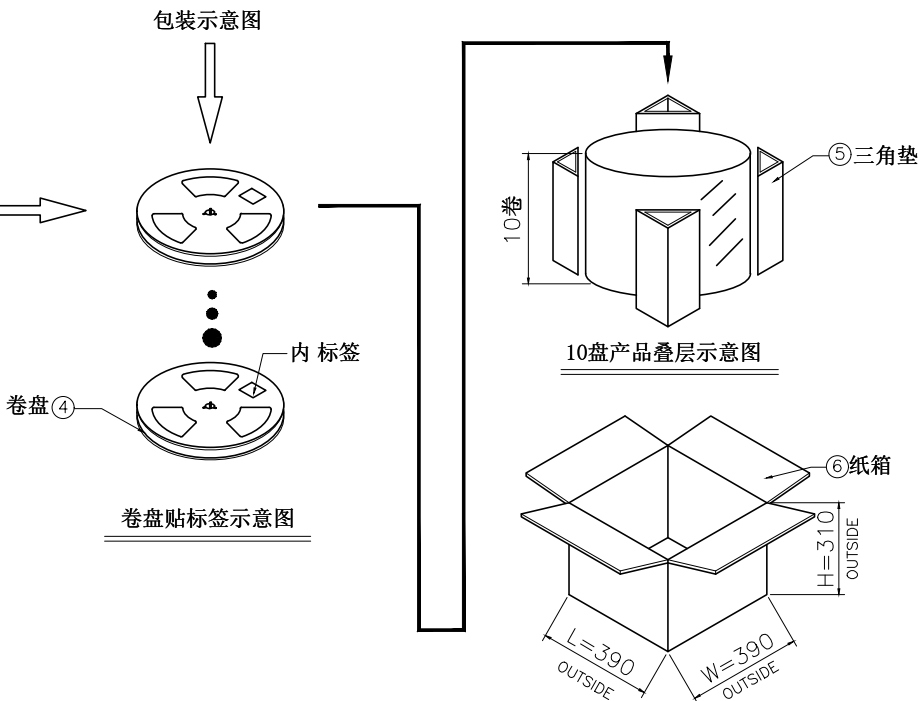
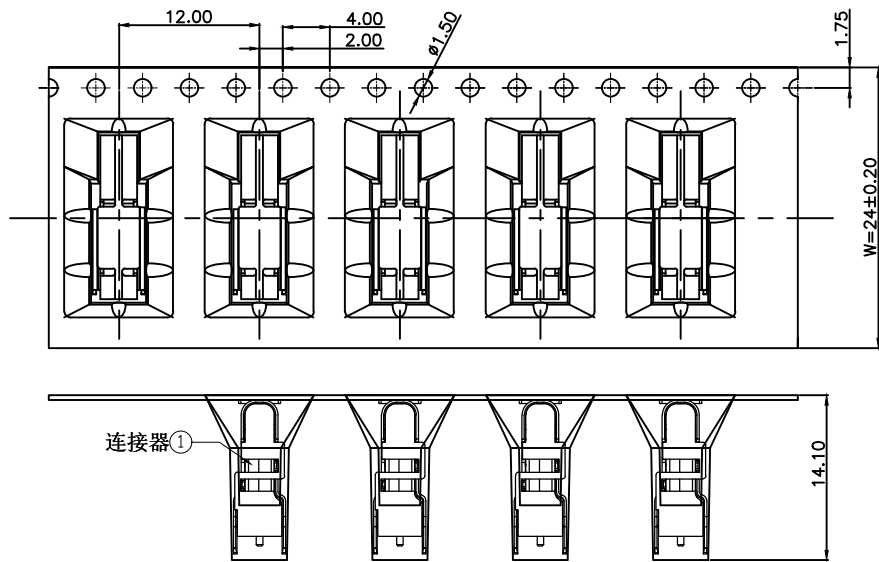

产品入载带示意图

剥离角度: 165°~180°
剥离力: 40gf~120gf
用户取件方向

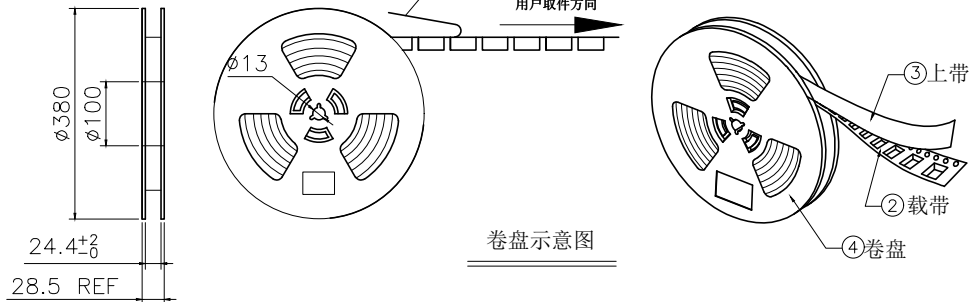

卷盘示意图

技术要求:

- 载带首尾各留出10PCS空格不装产品;
- 每穴放置1PCS产品, 每卷装550PCS产品, 放置方式如图所示;
- 将包装好的产品;每盘必需贴上内标签;将贴好内标签的产品每10盘堆叠。
- 在纸箱四角垫上4个三角垫, 然后把装好产品的卷盘放入纸箱中, 最后用胶带封箱; (如客户有要求, 请按客户要求包装出货)
- 上带与载带的剥离力: 40gf~120gf, 跳动量在30gf内; (剥离角度: 165°~180°, 剥离速度: 250~300mm/min)
- 产品符合RoHS环保标准要求。

06	纸箱	B-05-0012	390mm*390mm*310mm	1 PCS
05	三角垫	/	300mm*260mm*7mm	4 PCS
04	卷盘	/	D=380mm, d=100mm, H=28.5mm	10 PCS
03	上带	/	W=20.70mm, T=0.05mm	6840 mm
02	载带	B-03-0030	W=24mm, T=0.50mm, P=12.0mm	6840 mm
01	连接器	A032411A	24PIN, SMT	5500 PCS
序号	物料名称	物料编号	规格	描述

CUSTOMER DRAWING			铭创科技(东莞)有限公司		
UNITS mm	SCALE 1:1	SHEET 2 OF 2	Mingchuang Technology (Dongguan) Co., Ltd.		
PROJECTION: 	DRAW: DAP	TITLE TYPE C母座24PIN 侧贴四鱼叉脚插板SMT L=14.3 CH=7.20			
GENERAL TOLERANCE	CHECK: HWT	MAT'L	SEE TABLE	FINISH	SEE TABLE
.000 ±0.15 .00 ±0.20 .0 ±0.25 .0 ±2° .00 ±1°	APPD: HHM	DWG. NO.	A032411A	PART NO.	SIZE A4