

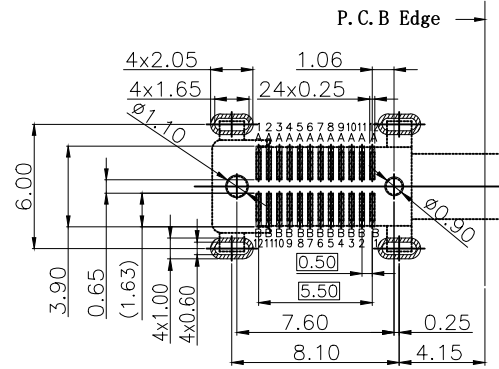

REV	DESCRIPTION	DATE	APPROVED
A	新版发行	2025.06.30	HHM

SPECIFICATION:

- ELECTRICAL:
 - CURRENT RATING:5A;
 - CONTACT RESISTANCE:40mΩ Max;
 - DIELECTRIC WITHSTANDING VOLTAGE:100V AC;
 - INSULATION RESISTANCE:100 MΩ MIN;
- MECHANICAL;
 - MATING FORCE:5~20N;
 - UNMATING FORCE:8~20N;
 - DURABILITY:10000 CYCLES;6~20N AFTER DURABILITY TEST;
- MATERIAL:
 - HOUSING&MOLDING: LCP BLACK UL94V-0;
 - TERMINAL:C18400 T=0.12mm;
 - SHELL:SUS304 T=0.30mm;
 - MID PLATE:SUS301 T=0.15mm;
- PLATING SPECIFICATION:
 - TERMINAL:CONTACT POINT GOLD PLATED 3u"MIN
PIN WELDING AREA GOLD PLATED 1u" MIN.
NI 40u" Min. UNDER PLATED OVER ALL.
 - SHELL:PLATED Ni 50u" MIN(Salt spray 48H)
- ELECTROPLATED PRODUCTS NEED TO UNDERGO TIN ADHESION TESTING: THE TIN ADHESION AREA SHOULD REACH OVER 95%.
- SMT REFLOW SOLDERING (PEAK VALUE 260 °C ± 5 ° C) SHALL BE FREE OF BLISTERING, GLUE MELTING AND POOR COLOR CHANGE (DEFORMATION WITHIN TOLERANCE)
- OPERATING TEMPERATURE: -40° C~+85° C

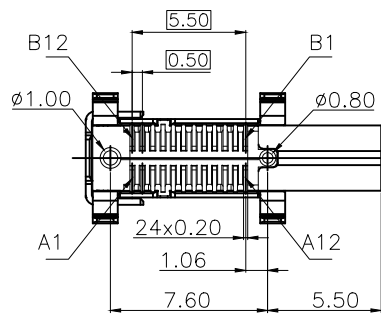
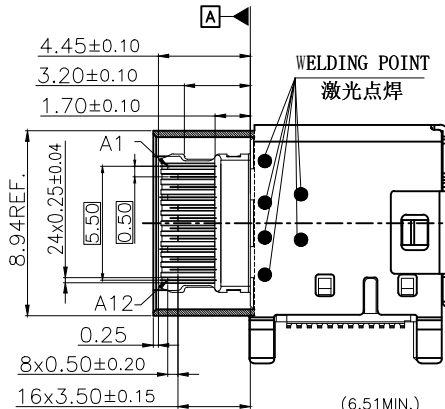
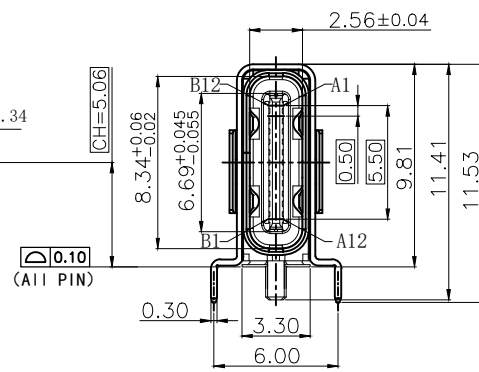
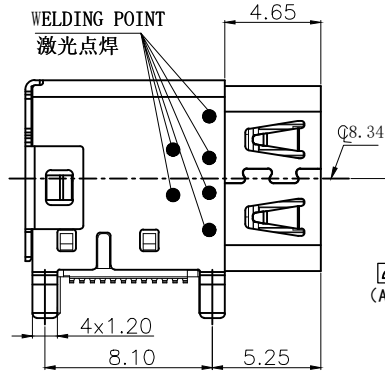
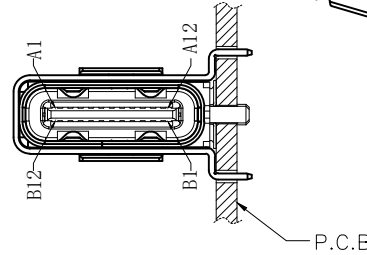
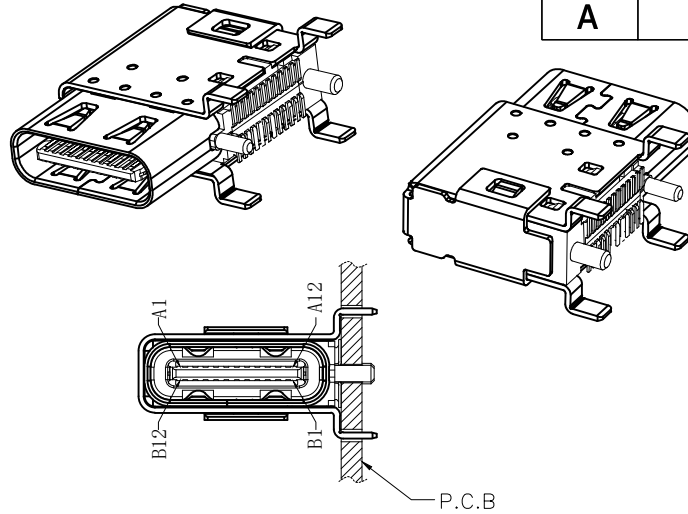
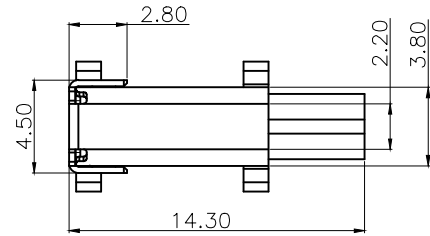

RECOMMENDED P.C.B. LAYOUT (TOP View)
TOLERANCE UNSPECIFIED ±0.05mm

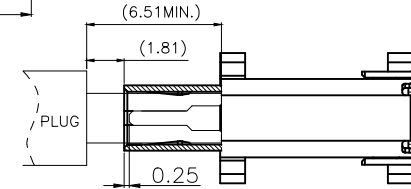

AFTER MATING

A1	GND	B12	GND
A2	TX1+	B11	RX1+
A3	TX1-	B10	RX1-
A4	VBUS	B9	VBUS
A5	CC1	B8	SBU2
A6	D+	B7	D-
A7	D-	B6	D+
A8	SBU1	B5	CC2
A9	VBUS	B4	VBUS
A10	RX2-	B3	TX2-
A11	RX2+	B2	TX2+
A12	GND	B1	GND
PIN	SIGNAL NAME	PIN	SIGNAL NAME

CUSTOMER DRAWING		
UNITS mm	SCALE 1:1	SHEET 1 OF 2
PROJECTION: 	DRAW: DAP	
GENERAL TOLERANCE .000 ±0.15 .00 ±0.20 .0 ±0.25 .0 ±2° .00 ±1°	CHECK: HWT	
	APPD: HHM	

铭创科技 (东莞) 有限公司 Mingchuang Technology (Dongguan) Co., Ltd.		
TITLE TYPE C母座24PIN 侧贴四脚插板SMT L=14.3 CH=5.06 双壳点焊		
MAT'L SEE TABLE	FINISH SEE TABLE	
DWG. NO. A032413A	PART NO.	SIZE A4



REV	DESCRIPTION	DATE	APPROVED
A	新版发行	2025.06.30	HHM

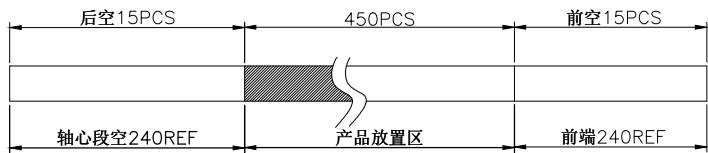
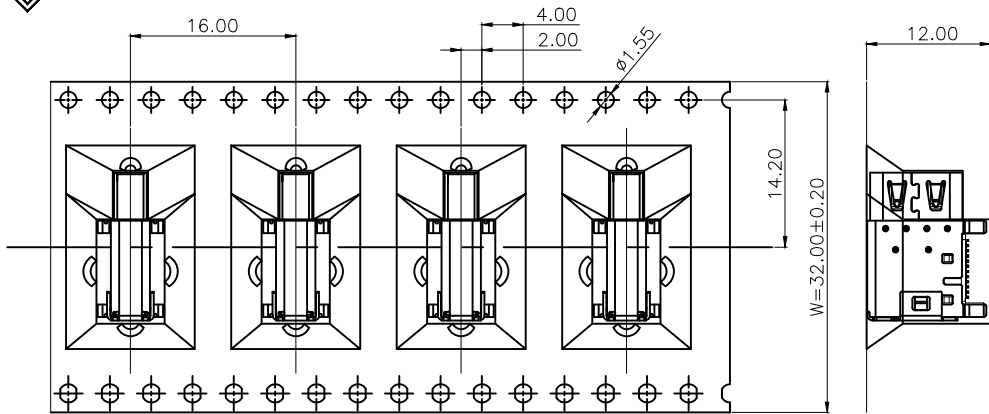

产品入载带示意图

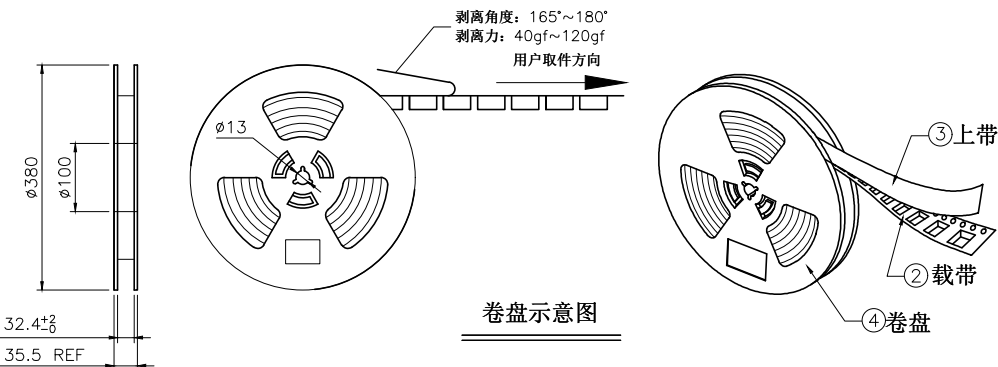
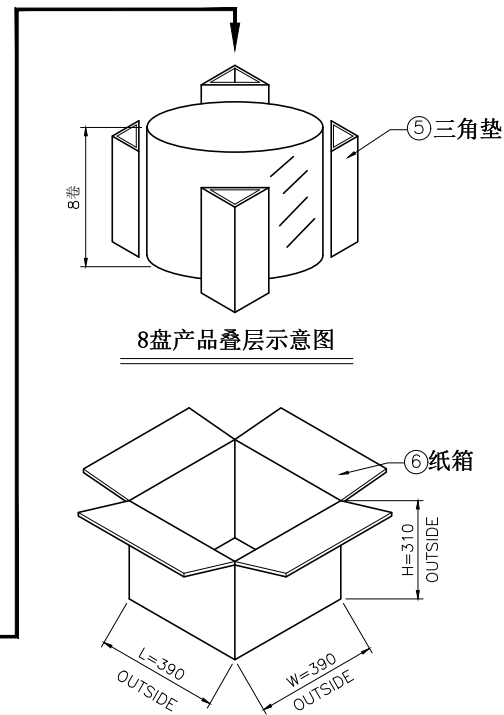
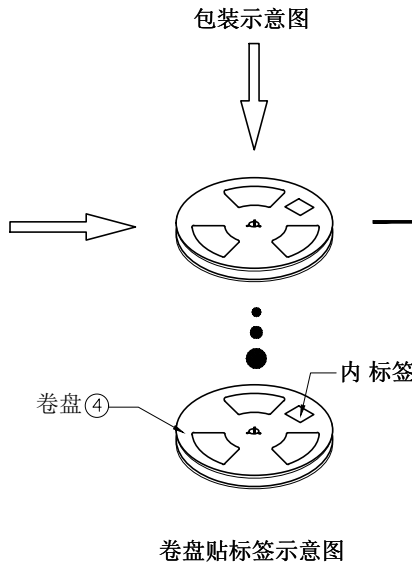

- 技术要求:
- 载带首尾各留出15PCS空格不装产品;
 - 每穴放置1PCS产品, 每卷装450PCS产品, 放置方式如图所示;
 - 将包装好的产品; 每盘必需贴上内标签; 将贴好内标签的产品每8盘堆叠.
 - 在纸箱四角垫上4个三角垫, 然后把装好产品的卷盘放入纸箱中, 最后用胶带封箱; (如客户有要求, 请按客户要求包装出货)
 - 上带与载带的剥离力: 40gf~120gf, 跳动量在30gf内; (剥离角度: 165°~180°, 剥离速度: 250~300mm/min)
 - 产品符合RoHS环保标准要求.

06	纸箱	B-05-0012	390mm*390mm*310mm	1 PCS
05	三角垫	/	300mm*260mm*7mm	4 PCS
04	卷盘	/	D=380mm, d=100mm, H=35.5mm	8 PCS
03	上带	/	W=25.5mm, T=0.05mm	7680 mm
02	载带	B-03-0047	T0.5*W32*P16mm	7680 mm
01	连接器	A032413A	24PIN, SMT	3600 PCS
序号	物料名称	物料编号	规格	描述

CUSTOMER DRAWING			铭创科技(东莞)有限公司 Mingchuang Technology (Dongguan) Co., Ltd.		
UNITS mm	SCALE 1:1	SHEET 2 OF 2	TITLE TYPE C母座24PIN 侧贴四脚插板SMT L=14.3 CH=5.06 双壳点焊		
PROJECTION: 		DRAW: DAP	MAT'L SEE TABLE FINISH SEE TABLE		
GENERAL TOLERANCE .000 ±0.15 .00 ±0.20 .0 ±0.25 .0 ±2° .00 ±1°		CHECK: HWT	DWG. NO. A032413A PART NO. SIZE A4		
		APPD: HHM			